



KIESELMANN

FLUID PROCESS GROUP

Translation of the original

Operating Instructions

Safety valves

Type 6146 - 6151

for gas



KIESELMANN GmbH

Paul-Kieselmann-Str. 4-10
D - 75438 Knittlingen

 +49(0) 7043 371-0 •  +49(0) 7043 371-125
www.kieselmann.de • info@kieselmann.de

Copyright: © KIESELMANN FLUID PROCESS GROUP

Table of contents

1	General informations	4
1.1	Informations for your safety	4
1.2	Marking of security instructions	4
1.3	General designated use	4
1.4	Personnel	4
1.5	Modifications, spare parts, accessories	5
1.6	General instructions	5
2	Safety instructions	6
2.1	Intended use	6
2.2	Unintended use	6
2.3	General notes	6
2.4	General safety instructions	6
3	Delivery, transport and storage	8
3.1	Delivery	8
3.2	Transport	8
3.3	Storage	8
4	Specification	9
4.1	Valve housing type	9
5	Function and operation	10
5.1	Description of function	10
5.2	Commissioning, service and maintenance	10
5.2.1	Commissioning	10
6	Technical data	11
6.1	Safety valves	11
6.2	Identification	11
7	Disassembly and assembly	12
7.1	Disassembly	12
8	Drawings and dimensions	13
8.1	Structure: Sealing ring design	13
8.2	Dimensions	14
9	Characteristic curves	16
9.1	Opening & closing characteristics	16
9.2	Blow-off performance chart	16
10	Appendix	20
10.1	Declaration of incorporation	20

1 General informations

1.1 Informations for your safety

We are pleased that you have decided for a high-class KIESELMANN product. With correct application and adequate maintenance, our products provide long time and reliable operation.





Before installation and initiation, please carefully read this instruction manual and the security advices contained in it. This guarantees reliable and safe operation of this product and your plant respectively. Please note that an incorrect application of the process components may lead to great material damages and personal injury.

In case of damages caused by non observance of this instruction manual, incorrect initiation, handling or external interference, guarantee and warranty will lapse!

Our products are produced, mounted and tested with high diligence. However, if there is still a reason for complaint, we will naturally try to give you entire satisfaction within the scope of our warranty. We will be at your disposal also after expiration of the warranty. In addition, you will also find all necessary instructions and spare part data for maintenance in this instruction manual. If you don't want to carry out the maintenance by yourself, our KIESELMANN - service team will naturally be at your disposal.

1.2 Marking of security instructions

Hints are available in the chapter "safety instructions" or directly before the respective operation instruction. The hints are highlighted with a danger symbol and a signal word. Texts beside these symbols have to be read and adhered to by all means. Please continue with the text and with the handling at the valve only afterwards.

Symbol	Signal word	Meaning
	DANGER	Imminent danger which will result severe personal injury or death.
	WARNING	Imminent danger which may result severe personal injury or death.
	CAUTION	Dangerous situation which may cause slight personal injury or material damages.
	NOTICE	An harmful situation which may result in damages of the product itself or of adjacent vicinity.
	INFORMATION	Marks application hints and other information which is particularly useful.

1.3 General designated use

The fitting is designed exclusively for the purposes described below. Using the fitting for purposes other than those mentioned is considered contrary to its designated use. KIESELMANN cannot be held liable for any damage resulting from such use. The risk of such misuse lies entirely with the user. The prerequisite for the reliable and safe operation of the fitting is proper transportation and storage as well as competent installation and assembly. Operating the fitting within the limits of its designated use also involves observing the operating, inspection and maintenance instructions.

1.4 Personnel

Personnel entrusted with the operation and maintenance of the tank safety system must have the suitable qualification to carry out their tasks. They must be informed about possible dangers and must understand and observe the safety instructions given in the relevant manual. Only allow qualified personnel to make electrical connections.

1.5 Modifications, spare parts, accessories

Unauthorized modifications, additions or conversions which affect the safety of the fitting are not permitted. Safety devices must not be bypassed, removed or made inactive. Only use original spare parts and accessories recommended by the manufacturer.

1.6 General instructions

The user is obliged to operate the fitting only when it is in good working order. In addition to the instructions given in the operating manual, please observe the relevant accident prevention regulations, generally accepted safety regulations, regulations effective in the country of installation, working and safety instructions effective in the user's plant.

2 Safety instructions

2.1 Intended use

This safety valve is used to prevent overpressure in tanks and vessels in plants of the food and drink industry, pharmaceutical and chemical industries as well as in biotechnology.

2.2 Unintended use

Safety valves must not be used improperly. In the event of improper use, the manufacturer is no longer liable.

Seals must not be damaged or removed. Changes may affect the operation and the performance of the safety valve. The guarantee is voided. Moving and functionally important parts must not be given a protective coating.

Safety valves must not be blocked.

2.3 General notes



NOTICE - observe the operating instructions

To avoid danger and damage, the fitting must be used in accordance with the safety instructions and technical data contained in the operating instructions.



NOTICE

All data are in line with the current state of development. Subject to change as a result of technical progress.

2.4 General safety instructions



⚠ WARNING

Risk of injury by outflowing medium

Dismantling the valve or valve assemblies from the plant can cause injuries.

- Media flowing through the leakage drain outlet are to be drained off without splashing into a discharge arrangement.
- Carry the disassembling only if when the plant has been rendered pressure-less and free of liquid and gas.



⚠ WARNING

Risk of injury by outflowing medium

With pressure greater than the set pressure the gaseous or liquid media will radial escape into the atmosphere via outlet drillings.

- It is necessary to install protection and drainage devices.



⚠ WARNING

Risk of injury by pre-stressed pressure spring.

The valve is spring preloaded. When disassembling the valve, components that jump out may cause injuries.

- Observe the instructions in chapter 'Disassembly and assembly'!

**⚠ WARNING****Changing the set pressure**

The set pressure is set at the factory and must not be changed.

- Pressure settings may only be made at the factory.
 - No liability is assumed for any cases of damage arising from changes to the delivery settings of the fittings.

**⚠ WARNING****ATEX - Guidelines**

If the valve or the plant is operated in a potentially explosive atmosphere, the valid ATEX directive of the EC and the installation instructions in this operating manual must be observed.

**⚠ CAUTION**

Before starting the system, the entire pipeline system must be thoroughly cleaned.

**⚠ CAUTION**

Steps should be taken to ensure that no external forces are exerted on the fitting.

3 Delivery, transport and storage

3.1 Delivery

- Immediately after receipt check the delivery for completeness and transport damages.
- Remove the packaging from the product.
- Retain packaging material, or expose of according to local regulations.

3.2 Transport



⚠ CAUTION

Risk of injury and damage to the product

During the transport the generally acknowledged rules of technology, the national accident prevention regulations and company internal work and safety regulations must be observed.

3.3 Storage



NOTICE

Damage to the product due to improper storage!

Observe storage instructions
avoid a prolonged storage



INFORMATION

Recommendation for longer storage

We recommend regularly checking the product and the prevailing storage conditions during long storage times.

- To avoid damage to seals and bearings,
 - products up to DN 125 / OD 5 inch should be stored horizontally for maximum 6 months.
 - products larger than DN 125 / 5 inch, should be stored in the upright position with the actuator on top.
- Don't store any objects on the products.
- Protect the products for wetness, dust and dirt.
- The product should be stored in a dry and well ventilated room at a constant temperature (optimal indoor temperature: 25 C ±5 ; indoor humidity data 70% ±5%).
- Protect seals, bearings and plastic parts for UV light and ozone.

4 Specification

4.1 Valve housing type

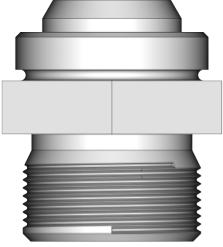
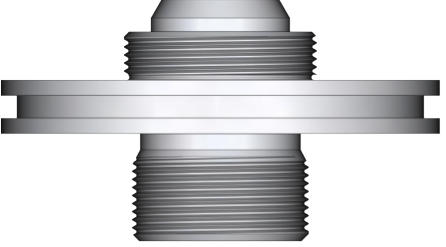
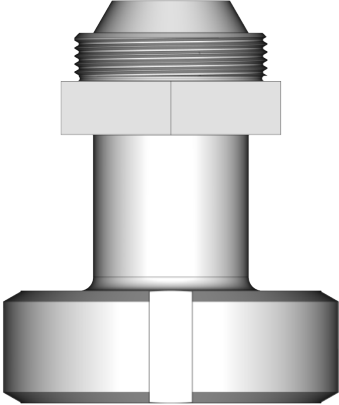
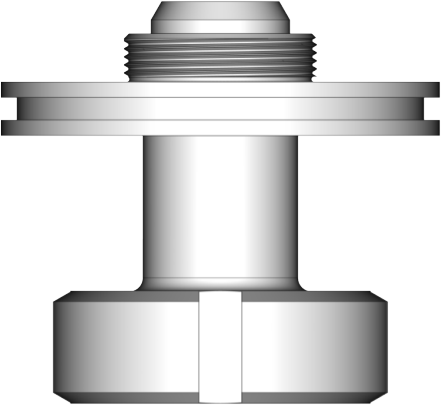
	Type 6146	Type 6150 with connection for cleaning unit
Threaded connection G1		
	Type 6147	Type 6151 with connection for cleaning unit
Cone socket with Slotted nut DIN 11851		

5 Function and operation

5.1 Description of function

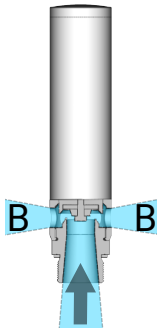

The safety valve is used to prevent inadmissible overpressure of gaseous media in tanks, containers and plant sections.

Generally, the set pressure is greater than the operating pressure. The valve opens against a spring force if the operating pressure increases to the set pressure.

With pressure increase analogous to the opening characteristic, the flow rate is dependent on the max. permissible operating pressure constantly discharged from the outlet drillings (B).

5.2 Commissioning, service and maintenance

5.2.1 Commissioning

5.2.1.1 Installation instructions



Installation Position

The safety valve must be installed vertically at connection "A" (see illustration right).

5.2.1.2 General welding guidelines

Sealing elements integrated in weld components must generally be removed prior to welding. To prevent damage, welding should be undertaken by certified personnel (EN ISO 9606-1). Use the TIG (Tungsten Inert Gas) welding process.



⚠ CAUTION

Damage and injuries due to high temperature supply

To avoid a distortion of the components, all welding parts must be welded to stress-relieved. Allow all components to cool before assembling.



! NOTICE

Damage due to impurities

Impurities can cause damage to the seals and seals area. Clean inside areas prior to assembly.

5.2.1.3 ATEX - Guidelines

For valves or plants/installations that are operated in the ATEX area, sufficient bonding (grounding) must be ensured (see valid ATEX Guidelines EG).

6 Technical data

6.1 Safety valves

Model	safety valve spring close for gaseous and vaporous media	
Size	DN20	
Connection type	Threaded connection G1 Threaded connection according <i>DIN 11851</i> Pipe fitting according to <i>DIN 11853-1</i> Flange connection according to <i>DIN 11853-2</i> Clamp connection according to <i>DIN 11853-3</i>	
Leakage rate	A (<i>EN 12266-1</i>)	
Pressure range	0,5 - 0,9 bar 0,8 - 1,9 bar 1,1 - 2,7 bar 2,5 - 8,0 bar	
Discharge coefficient	0.39	
Temperature range	Ambient temperature:	+4° to +45°C (air)
	Operating temperature:	+0° to +100°C (gases & steams)
	Sterilisation temperature:	EPDM +130°C (SIP 30 min) FKM +90°C
Material (in contact with product)	Stainless steel:	1.4404 / AISI 316L
	Surface:	$Ra \leq 0,8\mu m$, e-polished
	Sealing material:	EPDM (FDA) FKM (FDA)

6.2 Identification

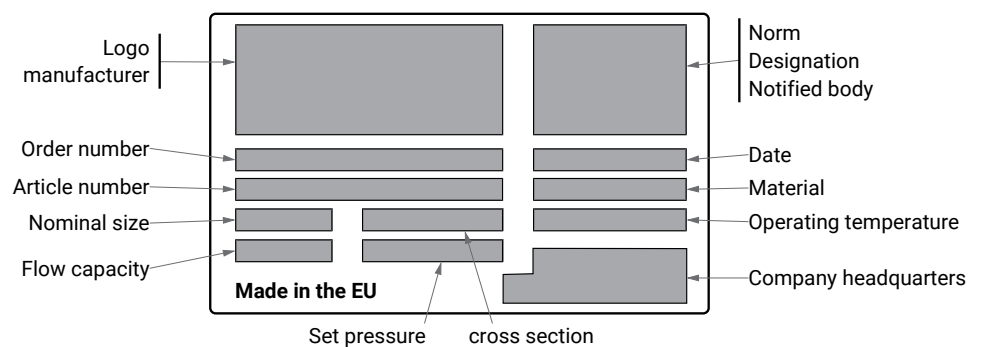

7 Disassembly and assembly

7.1 Disassembly



NOTICE

All screw connections have right-handed threads.

Disassembly

- Unscrew the upper valve housing (2) from the lower valve housing (1).

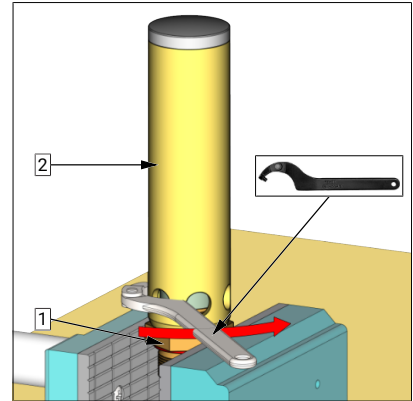

- Remove the seal (8).
- Remove the valve disc (4).

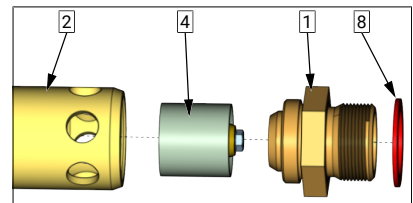

- Unscrew the hexagon screw (7).
- Remove the disc (6) and seal (5).

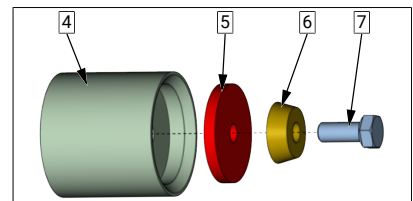

8 Drawings and dimensions

8.1 Structure: Sealing ring design

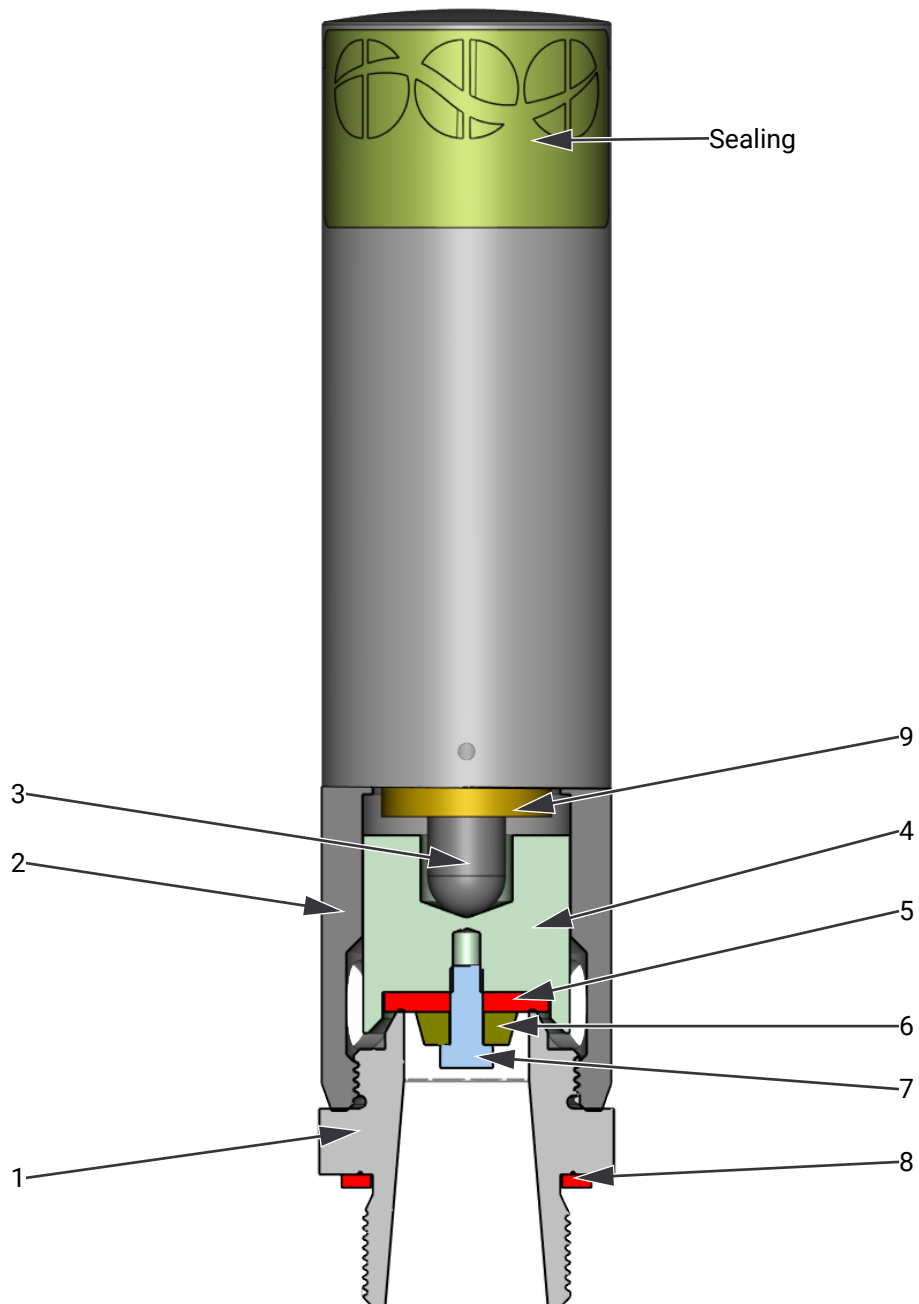

1 Tightly seat	2 Valve housing
3 Shaft	4 valve disc
5 Sealing ring	6 Thrust collar
7 Hexagon screw	8 Sealing ring
9 Spring disc	

8.2 Dimensions

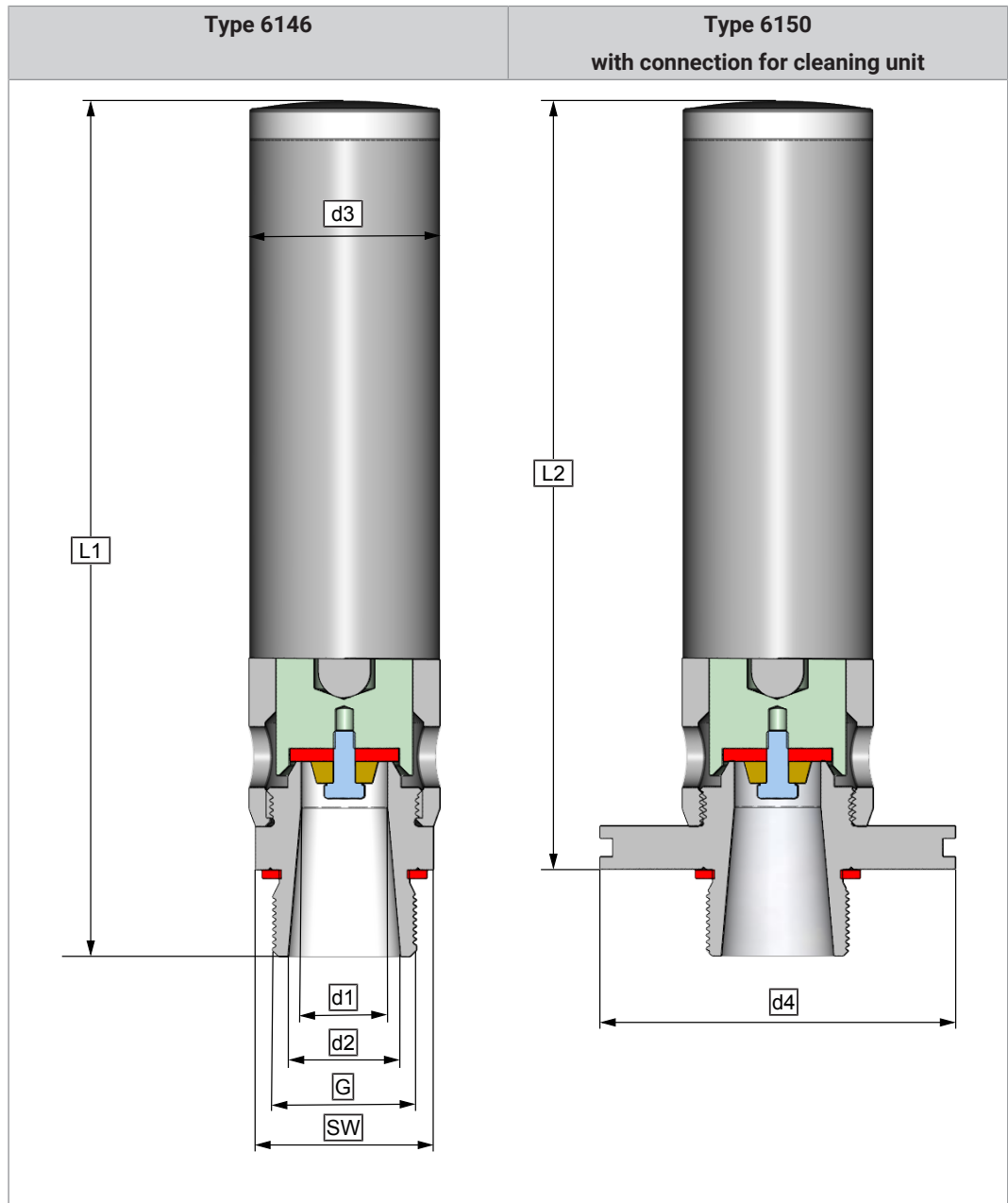

DN	G	d1	d2	d3	d4	L1	L2	SW
20	1"	Ø 20	Ø 26	Ø 44	Ø 82	~ 219	~ 177	41

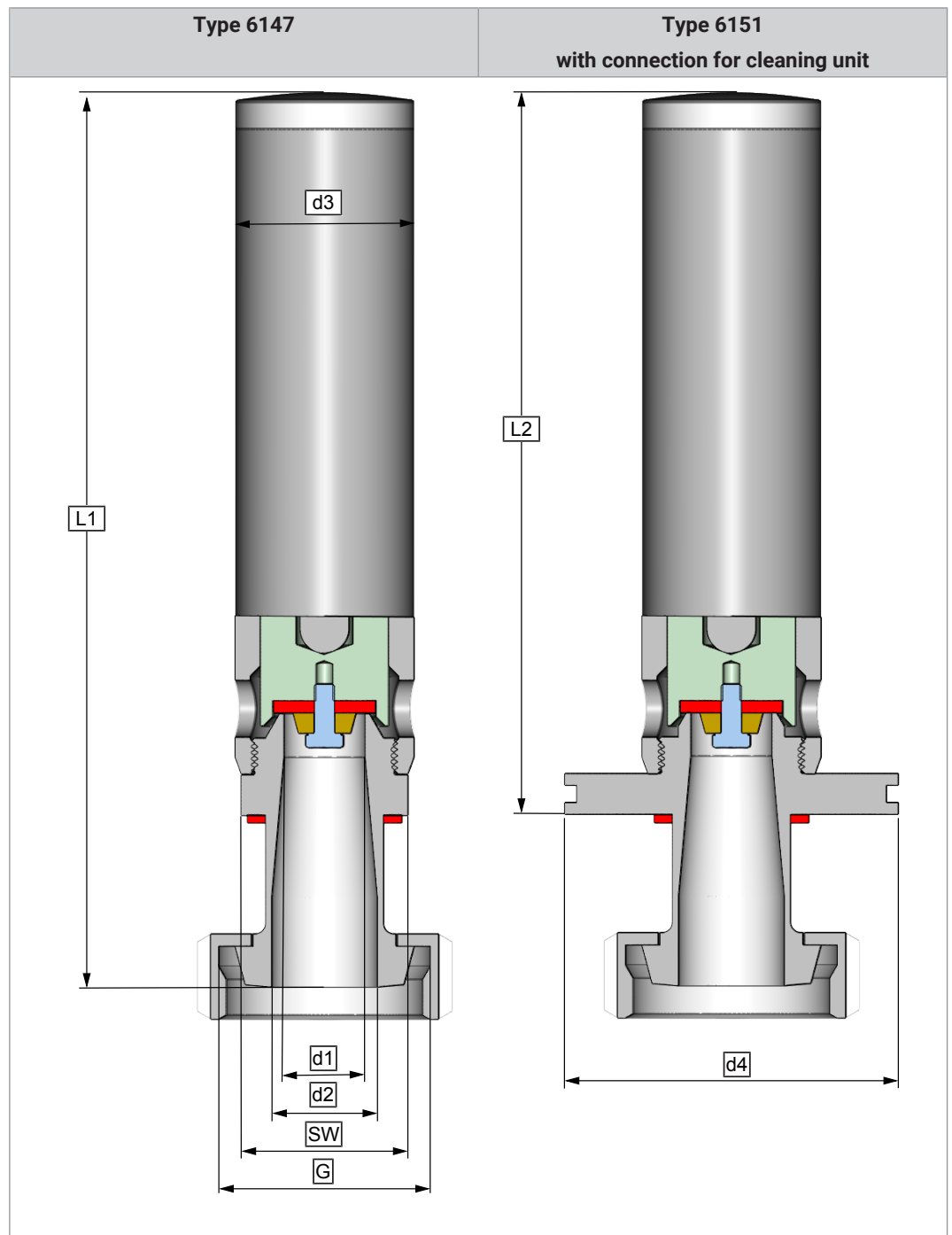

DN	G	d1	d2	d3	d4	L1	L2	SW
20 / 25	Rd52x1/6	Ø 20	Ø 26	Ø 44	Ø 82	~ 219	~ 177	41
20 / 32	Rd58x1/6	Ø 20	Ø 26	Ø 44	Ø 82	~ 219	~ 177	41
20 / 40	Rd65x1/6	Ø 20	Ø 26	Ø 44	Ø 82	~ 219	~ 177	41
20 / 50	Rd78x1/6	Ø 20	Ø 26	Ø 44	Ø 82	~ 219	~ 177	41
20 / 65	Rd95x1/6	Ø 20	Ø 26	Ø 44	Ø 82	~ 219	~ 177	41

9 Characteristic curves

9.1 Opening & closing characteristics

- Opening and closing characteristics for gas (air) 20°C

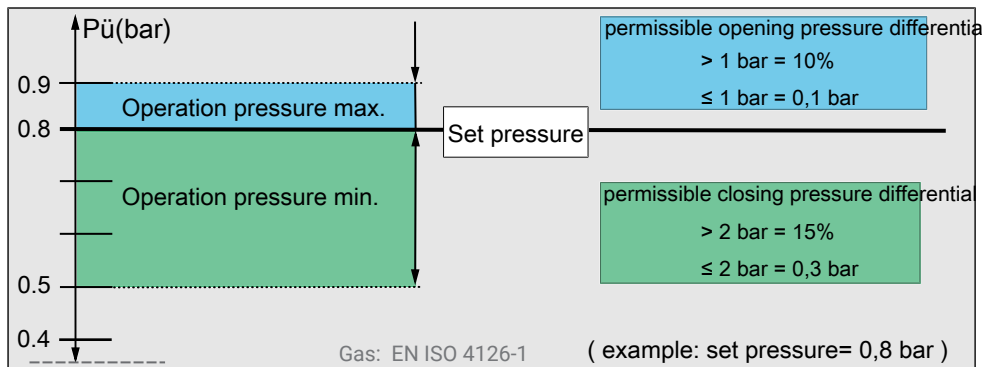
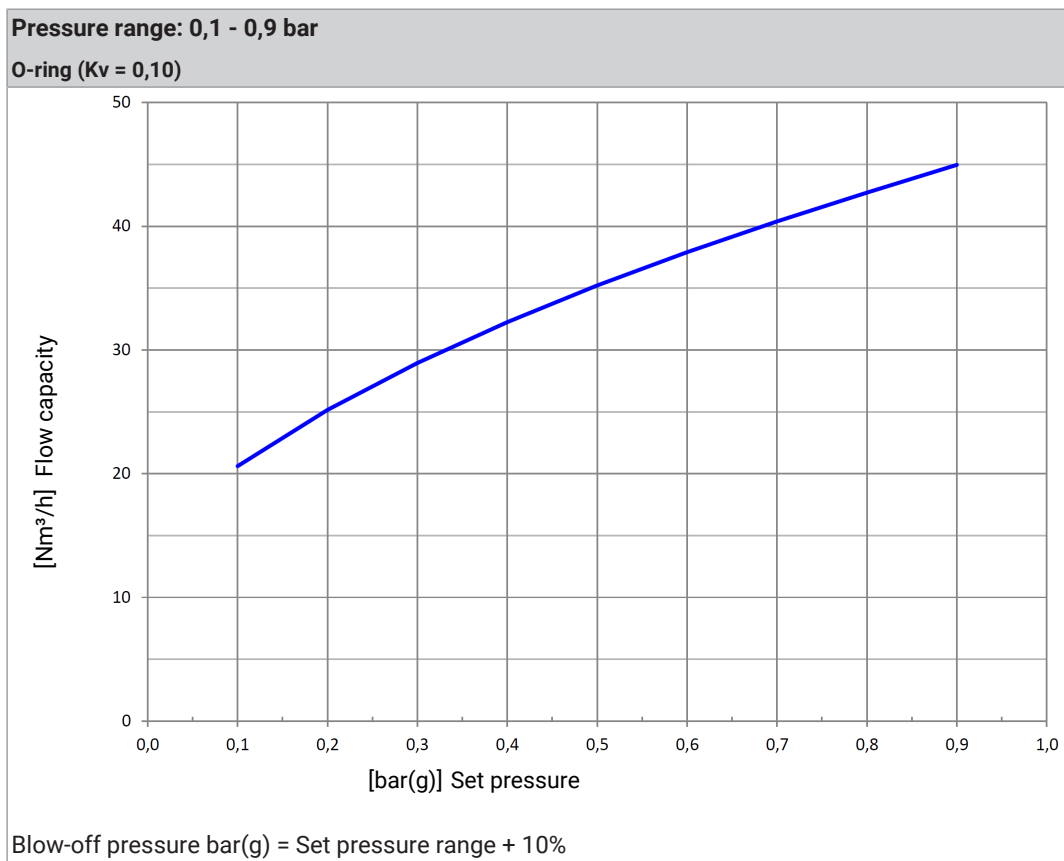
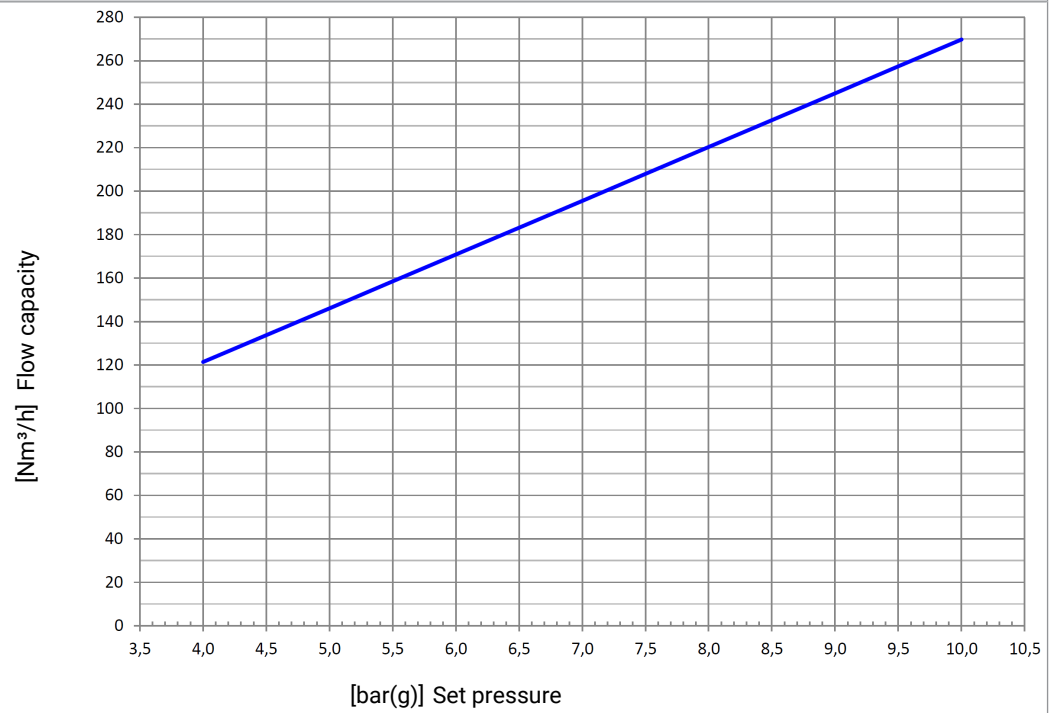

Fig. 1

9.2 Blow-off performance chart



Pressure range: 4,0 - 10,0 bar**O-ring (Kv = 0,10)**

Blow-off pressure bar(g) = Set pressure range + 10%

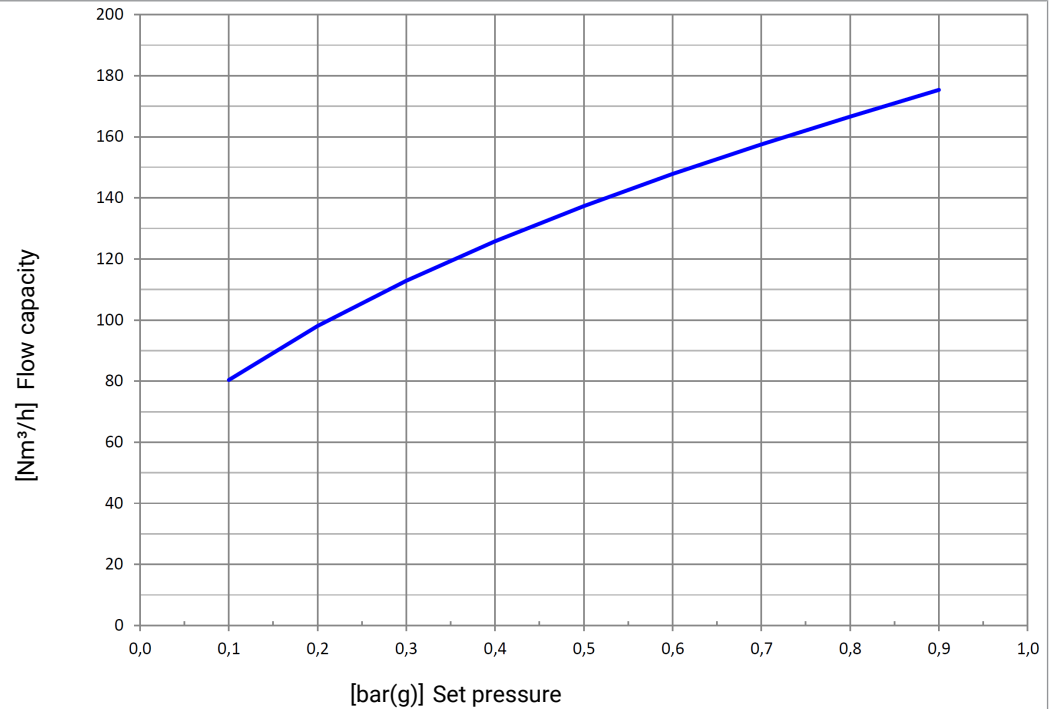
Pressure range: 0,1 - 0,9 bar**Seal disc (Kv = 0,39)**

Blow-off pressure bar(g) = Set pressure range + 10%

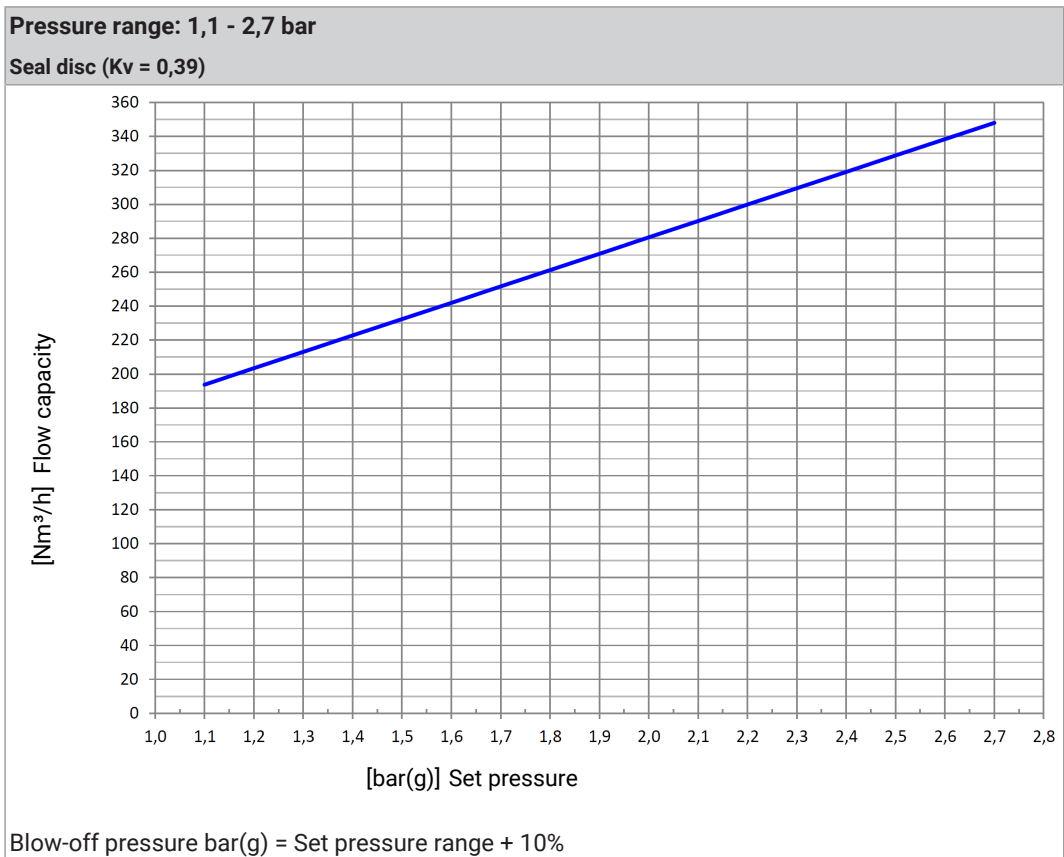
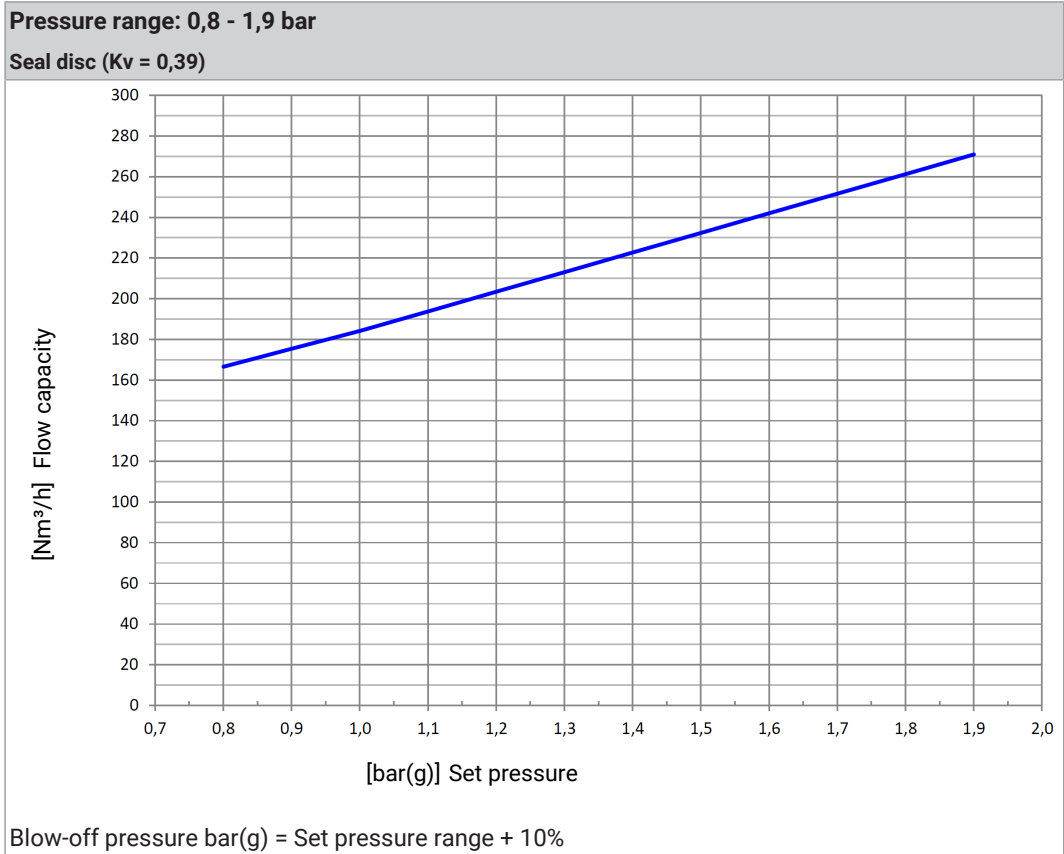

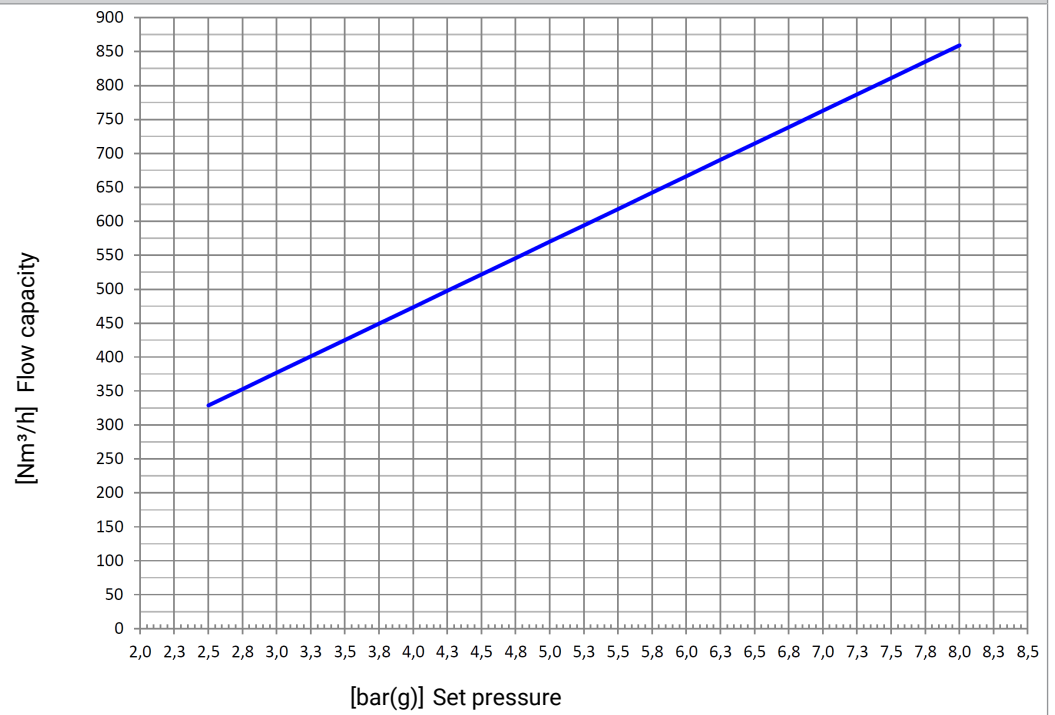
Pressure range: 2,5 - 8,0 bar**Seal disc (Kv = 0,39)**

Blow-off pressure bar(g) = Set pressure range + 10%

10 Appendix

10.1 Declaration of incorporation

Declaration of Incorporation

according to Directive 2006/42/EC of the European Parliament and the Council of 17 May 2006

Manufacturer:
KIESELMANN GmbH
Paul-Kieselmann-Str. 4-10
D-75438 Knittlingen

We declare that the following pressure equipment

Designation	Function
Pneumatic Linear actuator	pneumatically operation of valves
Pneumatic Quarter-turn actuator	pneumatically operation of valves
Butterfly Valve (pneumatically operated)	Separation of medium flow
Ball Valve (pneumatically operated)	Separation of medium flow
Single seat Valve (pneumatically operated)	Separation of medium flow
Changeover Valve (pneumatically operated)	Separation of medium flow
Double-Seat mixproof Valve (pneumatically operated)	Separation of medium flow
Control Valve (pneumatically operated)	Regulation of medium flow
Throttling Valve (pneumatically operated)	Regulation of medium flow
Tank Outlet Valve (pneumatically operated)	Separation of medium flow
Sampling Valve (pneumatically operated)	Separation of medium flow

complies with the definition of an „incomplete machine“ according to Article 2 of the European Machinery Directive 2006/42/EG, when fitted in or merged with other machines or incomplete machines which also comply with the provision of the Directive.

Applied harmonized standards:

Directive 2014/68/EU
EN ISO 12100

Person responsible for documentation:

Achim Kauselmann
Documentation / Development
KIESELMANN GmbH

Knittlingen, 10.10.2020

i.V. Uwe Heisswoff
Head of Development

KIESELMANN
FLUID PROCESS GROUP

Notes



KIESELMANN GmbH

Paul-Kieselmann-Str. 4-10
D - 75438 Knittlingen

☎ +49(0) 7043 371-0 • 📠 +49(0) 7043 371-125
www.kieselmann.de • info@kieselmann.de

Copyright: © KIESELMANN FLUID PROCESS GROUP